



US009510872B2

(12) **United States Patent**  
**Donner et al.**

(10) **Patent No.:** **US 9,510,872 B2**

(45) **Date of Patent:** **Dec. 6, 2016**

(54) **SPINAL STABILIZATION SYSTEM**

(71) Applicant: **JCBD, LLC**, Fort Collins, CO (US)

(72) Inventors: **Edward Jeffrey Donner**, Fort Collins, CO (US); **Christopher Thomas Donner**, Fort Collins, CO (US)

(73) Assignee: **JCBD, LLC**, Fort Collins, CO (US)

(\* ) Notice: Subject to any disclaimer, the term of this patent is extended or adjusted under 35 U.S.C. 154(b) by 0 days.

(21) Appl. No.: **14/209,138**

(22) Filed: **Mar. 13, 2014**

(65) **Prior Publication Data**

US 2014/0296917 A1 Oct. 2, 2014

**Related U.S. Application Data**

(60) Provisional application No. 61/794,543, filed on Mar. 15, 2013.

(51) **Int. Cl.**  
**A61B 17/70** (2006.01)

(52) **U.S. Cl.**  
CPC ..... **A61B 17/7071** (2013.01); **A61B 17/7043** (2013.01); **A61B 17/7026** (2013.01); **A61B 17/7067** (2013.01)

(58) **Field of Classification Search**  
CPC ..... A61B 17/7062; A61B 17/7071  
USPC ..... 606/246-253  
See application file for complete search history.

(56) **References Cited**

**U.S. PATENT DOCUMENTS**

4,488,542 A 12/1984 Helland  
4,569,338 A 2/1986 Edwards

4,590,928 A 5/1986 Hunt et al.  
4,714,469 A 12/1987 Kenna et al.  
4,773,402 A 9/1988 Asher et al.  
4,794,918 A 1/1989 Wolter  
4,920,958 A 5/1990 Walt et al.  
4,950,270 A 8/1990 Bowman et al.  
5,026,373 A 6/1991 Ray et al.  
5,192,327 A 3/1993 Brantigan  
5,242,444 A 9/1993 MacMillan  
5,282,861 A 2/1994 Kaplan et al.

(Continued)

**FOREIGN PATENT DOCUMENTS**

AU 1753200 A 8/2000  
CN 2265765 Y 10/1997

(Continued)

**OTHER PUBLICATIONS**

International Search Report and Written Opinion dated Aug. 19, 2014 from corresponding International patent application.

*Primary Examiner* — Ellen C Hammond

*Assistant Examiner* — Stuart S Bray

(74) *Attorney, Agent, or Firm* — Glenn H. Lenzen; Dietze and Davis, P.C.

(57) **ABSTRACT**

A spinal stabilization system is provided for maintaining preselected spacing and movement between adjacent vertebrae in a spinal column and for providing overall stability thereto. The system includes interlaminar members positioned in the spaces intermediate a first vertebra and the vertebrae positioned immediately above and immediately below and adjacent to the first vertebra. The interlaminar members are operatively connected to one another by an adjustable support structure and cooperate therewith to maintain the preselected spacing between adjacent vertebrae and to provide overall stability to the spinal column.

**24 Claims, 13 Drawing Sheets**

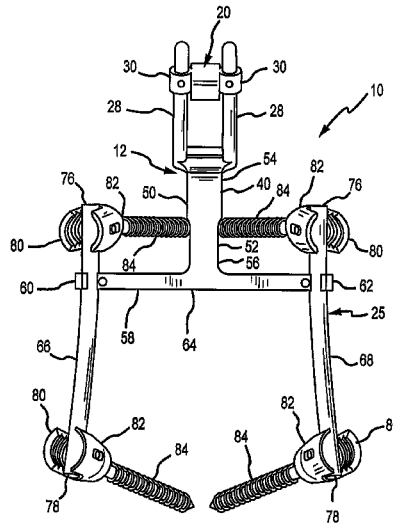

(56)

References Cited

U.S. PATENT DOCUMENTS

5,334,205	A	8/1994	Cain		7,819,869	B2	10/2010	Godara et al.
5,336,225	A	8/1994	Zang		7,824,404	B2	11/2010	Godara et al.
5,415,661	A *	5/1995	Holmes	606/255	7,837,732	B2	11/2010	Zucherman et al.
5,437,674	A	8/1995	Worcel et al.		7,837,734	B2	11/2010	Zucherman et al.
5,443,509	A	8/1995	Boucher et al.		7,846,162	B2	12/2010	Nelson et al.
5,456,267	A	10/1995	Stark		7,850,719	B2	12/2010	Gournay et al.
5,593,407	A	1/1997	Reis		7,850,732	B2	12/2010	Heinz
5,607,424	A	3/1997	Tropiano et al.		7,909,871	B2	3/2011	Abdou
5,609,635	A	3/1997	Michelson		7,922,765	B2	4/2011	Reiley
5,609,636	A	3/1997	Kohrs et al.		7,972,382	B2	7/2011	Foley et al.
5,626,434	A	5/1997	Cook		8,075,561	B2	12/2011	Wolter
5,645,599	A *	7/1997	Samani	623/17.16	8,162,981	B2	4/2012	Vestgaarden
5,658,337	A	8/1997	Kohrs et al.		8,221,428	B2	7/2012	Trieu
5,669,909	A	9/1997	Zdeblick et al.		8,262,697	B2 *	9/2012	Kirschman 606/248
5,688,284	A	11/1997	Chervitz et al.		8,568,453	B2 *	10/2013	Abdou 606/248
5,702,452	A	12/1997	Argenson		8,801,757	B2 *	8/2014	Abdou 606/248
5,743,914	A	4/1998	Skiba		2001/0005796	A1	6/2001	Zdeblick et al.
5,772,524	A	6/1998	Barrick et al.		2002/0032484	A1	3/2002	Hyde, Jr.
5,919,193	A	7/1999	Slavitt		2002/0087161	A1	7/2002	Randall et al.
5,928,239	A	7/1999	Mirza et al.		2002/0116000	A1 *	8/2002	Zucherman et al. 606/61
5,993,463	A	11/1999	Truwit et al.		2002/0147449	A1 *	10/2002	Yun 606/61
6,053,916	A	4/2000	Moore et al.		2002/0183846	A1	12/2002	Kuslich et al.
6,063,442	A	5/2000	Cohen et al.		2003/0109928	A1	6/2003	Pasquet et al.
6,175,758	B1	1/2001	Kambin		2003/0114931	A1	6/2003	Lee et al.
6,236,891	B1	5/2001	Ingle et al.		2003/0171750	A1 *	9/2003	Chin 606/61
6,302,885	B1	10/2001	Essiger		2004/0073216	A1	4/2004	Lieberman
6,322,562	B1	11/2001	Wolter		2004/0117017	A1 *	6/2004	Pasquet et al. 623/17.11
6,413,278	B1	7/2002	Marchosky		2004/0220668	A1	11/2004	Eisermann et al.
6,432,107	B1	8/2002	Ferree		2004/0228901	A1	11/2004	Trieu et al.
6,547,795	B2	4/2003	Schneiderman		2005/0033434	A1 *	2/2005	Berry 623/17.14
6,547,823	B2	4/2003	Scarborough et al.		2005/0131409	A1 *	6/2005	Chervitz et al. 606/61
6,565,605	B2 *	5/2003	Goble et al.	623/17.11	2005/0149192	A1	7/2005	Zucherman et al.
6,579,318	B2	6/2003	Varga et al.		2005/0154391	A1	7/2005	Doherty et al.
6,607,487	B2	8/2003	Chang et al.		2005/0203515	A1	9/2005	Doherty et al.
6,635,059	B2	10/2003	Randall et al.		2005/0240264	A1	10/2005	Tokish et al.
6,660,224	B2	12/2003	Lefebvre et al.		2005/0245925	A1	11/2005	Iki et al.
6,669,698	B1	12/2003	Tromanhauser et al.		2005/0267482	A1	12/2005	Hyde
6,682,563	B2	1/2004	Scharf		2005/0273099	A1	12/2005	Baccelli et al.
6,682,567	B1	1/2004	Schroeder		2006/0015181	A1	1/2006	Elberg
6,716,245	B2	4/2004	Pasquet et al.		2006/0054171	A1	3/2006	Dall
6,723,099	B1	4/2004	Goshert		2006/0069438	A1	3/2006	Zucherman et al.
6,743,256	B2	6/2004	Mason		2006/0069439	A1	3/2006	Zucherman et al.
6,746,451	B2	6/2004	Middleton et al.		2006/0095134	A1	5/2006	Trieu et al.
6,824,564	B2	11/2004	Crozet		2006/0142759	A1 *	6/2006	Arnin et al. 606/61
6,835,208	B2	12/2004	Marchosky		2006/0147332	A1	7/2006	Jones et al.
6,855,167	B2	2/2005	Shimp et al.		2006/0161154	A1	7/2006	McAfee
6,902,567	B2	6/2005	Del Medico		2006/0217718	A1 *	9/2006	Chervitz et al. 606/61
6,908,465	B2	6/2005	von Hoffmann et al.		2006/0224159	A1 *	10/2006	Anderson 606/61
6,945,488	B2	9/2005	Shimanuki et al.		2006/0241601	A1 *	10/2006	Trautwein et al. 606/61
6,974,461	B1	12/2005	Wolter		2006/0241642	A1 *	10/2006	Arnin et al. 606/90
7,011,660	B2	3/2006	Sherman et al.		2006/0241757	A1 *	10/2006	Anderson 623/17.11
7,087,058	B2	8/2006	Cragg		2007/0027543	A1	2/2007	Gimble et al.
7,108,828	B2	9/2006	Lefebvre et al.		2007/0055374	A1	3/2007	Copf et al.
7,201,775	B2	4/2007	Gorensek et al.		2007/0123861	A1	5/2007	Dewey
7,208,222	B2	4/2007	Rolfe et al.		2007/0156241	A1	7/2007	Reiley et al.
7,217,291	B2	5/2007	Zucherman et al.		2007/0162000	A1 *	7/2007	Perkins 606/61
7,235,101	B2	6/2007	Berry et al.		2007/0162134	A1	7/2007	Marnay et al.
7,255,712	B1	8/2007	Steinberg		2007/0179621	A1	8/2007	McClellan et al.
7,331,995	B2	2/2008	Eisermann et al.		2007/0198093	A1	8/2007	Brodke et al.
7,396,360	B2	7/2008	Lieberman		2007/0233068	A1	10/2007	Bruneau
7,410,501	B2	8/2008	Michelson		2007/0233129	A1	10/2007	Bertagnoli
7,458,991	B2	12/2008	Wang et al.		2007/0265621	A1	11/2007	Matthis et al.
7,465,317	B2	12/2008	Malberg et al.		2007/0270879	A1	11/2007	Isaza et al.
7,575,600	B2	8/2009	Zucherman et al.		2008/0009861	A1	1/2008	Stark
7,621,939	B2	11/2009	Zucherman et al.		2008/0015609	A1	1/2008	Trautwein
7,635,447	B2	12/2009	Hamman et al.		2008/0021454	A1	1/2008	Chao et al.
7,637,954	B2	12/2009	Michelson		2008/0021455	A1	1/2008	Chao et al.
7,648,509	B2	1/2010	Stark		2008/0021456	A1	1/2008	Gupta et al.
7,666,209	B2	2/2010	Zucherman et al.		2008/0039843	A1	2/2008	Abdou
7,699,873	B2 *	4/2010	Stevenson et al.	606/250	2008/0065215	A1	3/2008	Reiley
7,704,279	B2	4/2010	Moskowitz et al.		2008/0140082	A1	6/2008	Erdem et al.
7,740,795	B2	6/2010	Wang et al.		2008/0177264	A1 *	7/2008	Alamin et al. 606/74
7,789,895	B2	9/2010	Heinz		2008/0177326	A1 *	7/2008	Thompson 606/277
7,794,465	B2	9/2010	Marik et al.		2008/0228225	A1 *	9/2008	Trautwein et al. 606/246
7,799,081	B2	9/2010	McKinley		2008/0228276	A1	9/2008	Mathews et al.
					2008/0234733	A1 *	9/2008	Scrantz et al. 606/246
					2008/0269904	A1 *	10/2008	Voorhies 623/17.16
					2008/0281361	A1	11/2008	Vittur
					2008/0288081	A1	11/2008	Scrafton et al.

(56)

References Cited

U.S. PATENT DOCUMENTS

2008/0300685 A1 12/2008 Carls et al.  
 2008/0306525 A1\* 12/2008 Mitchell et al. .... 606/246  
 2009/0018660 A1 1/2009 Roush  
 2009/0018662 A1\* 1/2009 Pasquet et al. .... 623/17.16  
 2009/0024169 A1\* 1/2009 Triplett et al. .... 606/248  
 2009/0024174 A1 1/2009 Stark  
 2009/0076553 A1 3/2009 Wolter  
 2009/0088849 A1 4/2009 Armstrong et al.  
 2009/0099610 A1 4/2009 Johnson et al.  
 2009/0131986 A1 5/2009 Lee et al.  
 2009/0138048 A1\* 5/2009 Baccelli et al. .... 606/263  
 2009/0138053 A1 5/2009 Assell et al.  
 2009/0149885 A1\* 6/2009 Durward et al. .... 606/246  
 2009/0187217 A1 7/2009 Weiman  
 2009/0202150 A1 8/2009 Fradkin et al.  
 2009/0204151 A1 8/2009 Bracken  
 2009/0216238 A1 8/2009 Stark  
 2009/0216276 A1\* 8/2009 Pasquet ..... 606/249  
 2009/0259261 A1\* 10/2009 Reiley ..... 606/329  
 2009/0264929 A1\* 10/2009 Alamin et al. .... 606/248  
 2009/0270920 A1\* 10/2009 Douget et al. .... 606/254  
 2009/0287254 A1 11/2009 Nayet et al.  
 2009/0292314 A1\* 11/2009 Mangione et al. .... 606/249  
 2009/0306671 A1 12/2009 McCormack et al.  
 2010/0010496 A1\* 1/2010 Isaza et al. .... 606/96  
 2010/0049252 A1 2/2010 Smisson  
 2010/0069965 A1\* 3/2010 Abdou ..... 606/279  
 2010/0094290 A1 4/2010 Vaidya  
 2010/0100135 A1 4/2010 Phan  
 2010/0106200 A1 4/2010 Stark  
 2010/0131011 A1 5/2010 Stark  
 2010/0137919 A1 6/2010 Wolter  
 2010/0152785 A1 6/2010 Forton et al.  
 2010/0179552 A1 7/2010 Wolter  
 2010/0268228 A1 10/2010 Petersen  
 2010/0292738 A1 11/2010 Reiley  
 2010/0292800 A1 11/2010 Zubok  
 2010/0305702 A1 12/2010 Michelson  
 2010/0331981 A1 12/2010 Mohammed  
 2011/0009869 A1 1/2011 Marino et al.  
 2011/0034957 A1\* 2/2011 Biedermann ..... 606/305  
 2011/0071568 A1\* 3/2011 Ginn et al. .... 606/249  
 2011/0071635 A1 3/2011 Zhang et al.  
 2011/0087294 A1 4/2011 Reiley  
 2011/0087296 A1 4/2011 Reiley et al.  
 2011/0098816 A1 4/2011 Jacob et al.  
 2011/0098817 A1 4/2011 Eckhardt et al.  
 2011/0106163 A1\* 5/2011 Hochschuler et al. .... 606/264  
 2011/0106257 A1 5/2011 Matge  
 2011/0118785 A1 5/2011 Reiley  
 2011/0118790 A1 5/2011 Reiley  
 2011/0118796 A1 5/2011 Reiley et al.  
 2011/0118841 A1 5/2011 Reiley  
 2011/0125268 A1 5/2011 Reiley  
 2011/0137345 A1 6/2011 Stoll  
 2011/0160772 A1\* 6/2011 Arcenio et al. .... 606/248  
 2011/0166575 A1 7/2011 Assell et al.  
 2011/0184518 A1 7/2011 Trieu  
 2011/0184520 A1 7/2011 Trieu  
 2011/0185306 A1 7/2011 Aravamudan  
 2011/0190819 A1 8/2011 Trautwein  
 2011/0196427 A1 8/2011 Trautwein  
 2011/0218571 A1\* 9/2011 Attia ..... 606/248

2011/0230966 A1 9/2011 Trieu  
 2011/0264229 A1 10/2011 Donner  
 2012/0022535 A1 1/2012 Mayer et al.  
 2012/0022595 A1 1/2012 Pham et al.  
 2012/0065683 A1\* 3/2012 Kuo et al. .... 606/248  
 2012/0078303 A1 3/2012 Malek  
 2012/0095560 A1 4/2012 Donner  
 2012/0109198 A1\* 5/2012 Dryer et al. .... 606/248  
 2012/0109202 A1\* 5/2012 Kretzer et al. .... 606/248  
 2012/0130427 A1\* 5/2012 Hoffman et al. .... 606/248  
 2012/0136390 A1\* 5/2012 Butler et al. .... 606/248  
 2012/0150228 A1\* 6/2012 Zappacosta et al. .... 606/248  
 2012/0158060 A1\* 6/2012 Abrahams et al. .... 606/248  
 2012/0184997 A1\* 7/2012 Simonson ..... 606/265  
 2012/0215262 A1\* 8/2012 Culbert et al. .... 606/279  
 2012/0226312 A1\* 9/2012 Thalgott et al. .... 606/246  
 2012/0226314 A1\* 9/2012 Chin et al. .... 606/249  
 2012/0253398 A1 10/2012 Metcalf et al.  
 2012/0259370 A1\* 10/2012 Vaidya ..... 606/281  
 2012/0296428 A1\* 11/2012 Donner ..... 623/17.11  
 2013/0018427 A1 1/2013 Pham et al.  
 2013/0023933 A1\* 1/2013 Haas ..... 606/248  
 2013/0030467 A1\* 1/2013 Karas et al. .... 606/248  
 2013/0035727 A1\* 2/2013 Datta ..... 606/279  
 2013/0053854 A1\* 2/2013 Schoenefeld et al. .... 606/87  
 2013/0053902 A1 2/2013 Trudeau  
 2013/0072979 A1\* 3/2013 Butler et al. .... 606/248  
 2013/0296939 A1\* 11/2013 Perkins ..... 606/249  
 2013/0345753 A1 12/2013 Kretzer  
 2014/0052183 A1\* 2/2014 Freese ..... 606/248  
 2014/0074166 A1 3/2014 Scarrow  
 2014/0316467 A1\* 10/2014 Siegal et al. .... 606/249  
 2015/0012040 A1\* 1/2015 Agarwal et al. .... 606/248  
 2015/0182263 A1\* 7/2015 Donner et al. .... 606/248

FOREIGN PATENT DOCUMENTS

CN 201139628 Y 10/2008  
 CN 201275132 Y 7/2009  
 CN 201275133 Y 7/2009  
 CN 201275134 Y 7/2009  
 DE D606195 12/2009  
 KR 101037206 B1 5/2011  
 RU 2364359 C1 8/2009  
 WO 93/08745 A1 5/1993  
 WO 95/23559 9/1995  
 WO 01/95823 A1 12/2001  
 WO 02/03895 A1 1/2002  
 WO 02/067759 A2 9/2002  
 WO 2006/020463 A1 2/2006  
 WO 2007/022790 A1 3/2007  
 WO 2007/115295 A2 10/2007  
 WO 2008/011410 A2 1/2008  
 WO 2008/089537 A1 7/2008  
 WO 2009-011774 A2 1/2009  
 WO 2009-029074 A1 3/2009  
 WO 2009/108318 A2 9/2009  
 WO 2010/045749 A1 4/2010  
 WO 2010/065015 A1 6/2010  
 WO 2011/056690 A2 5/2011  
 WO 2011/066053 A2 6/2011  
 WO 2011-091349 A2 7/2011  
 WO 2012/015976 A1 2/2012  
 WO 2013/020123 A2 2/2013

\* cited by examiner



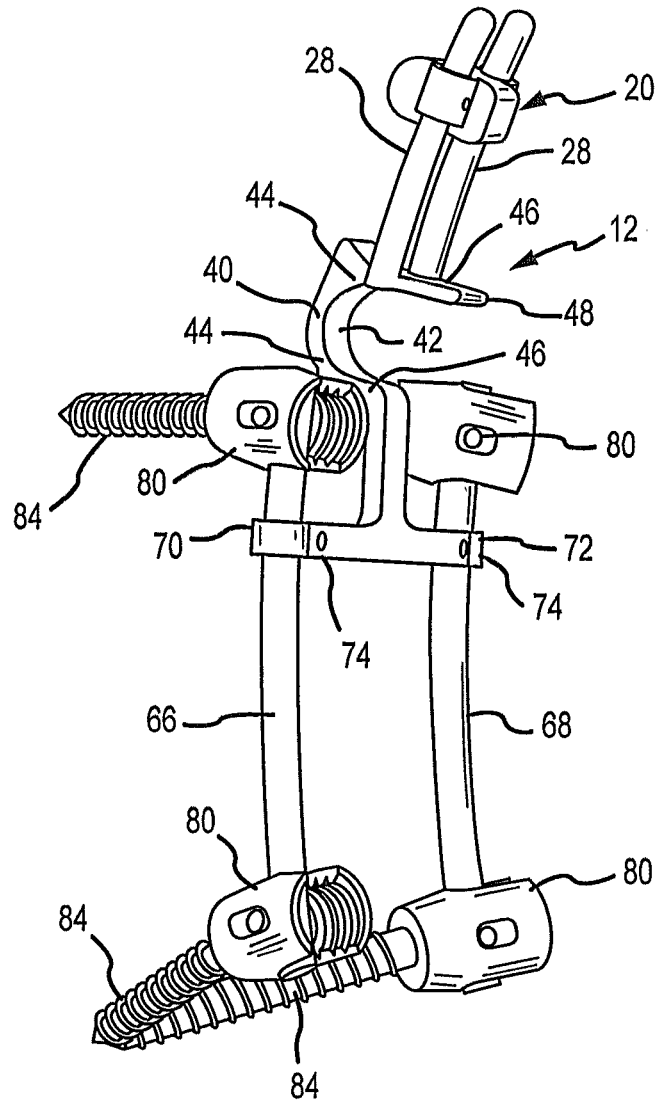

FIG.2

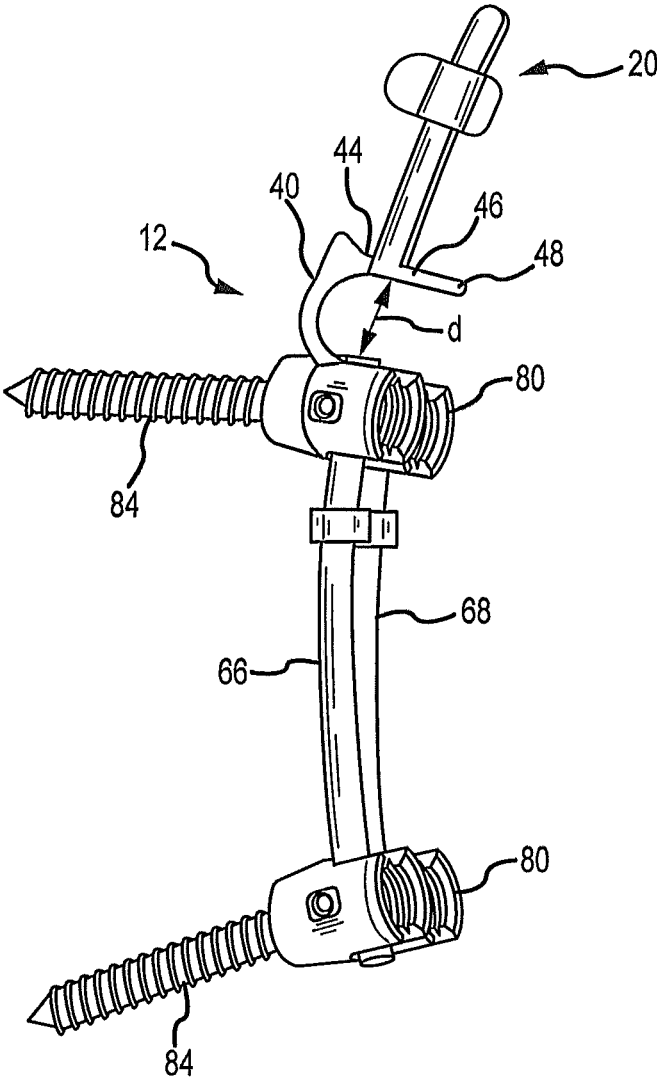

FIG.3

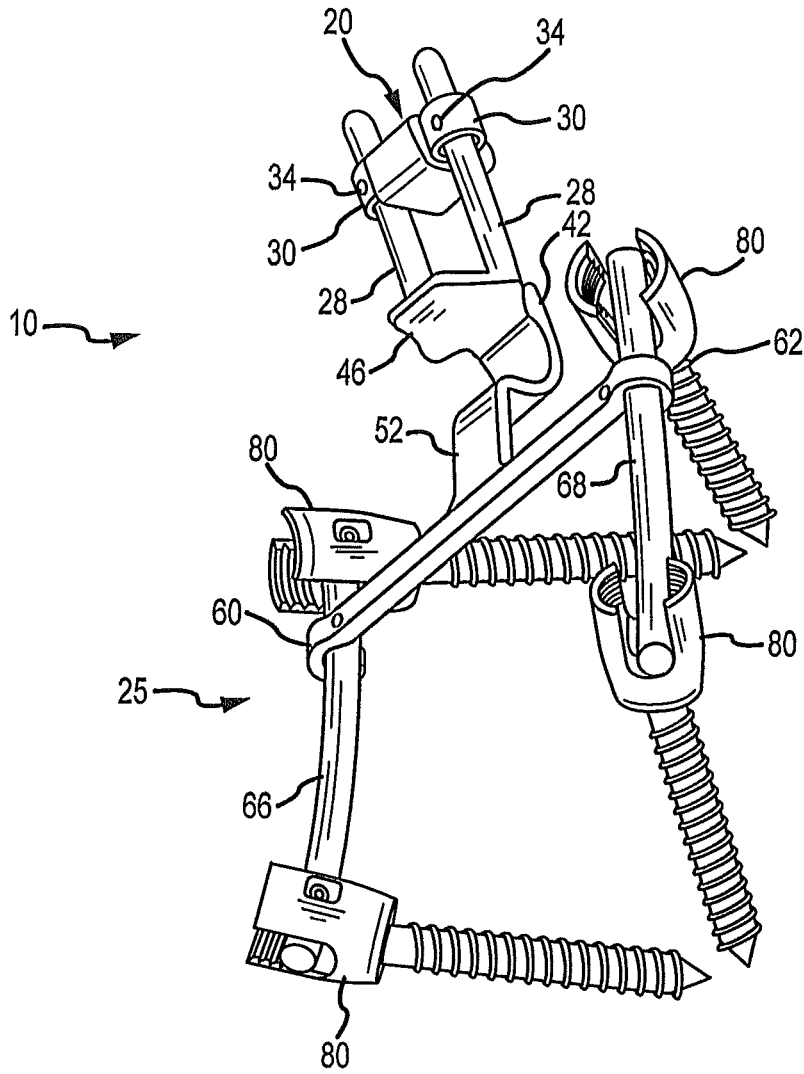

FIG.4

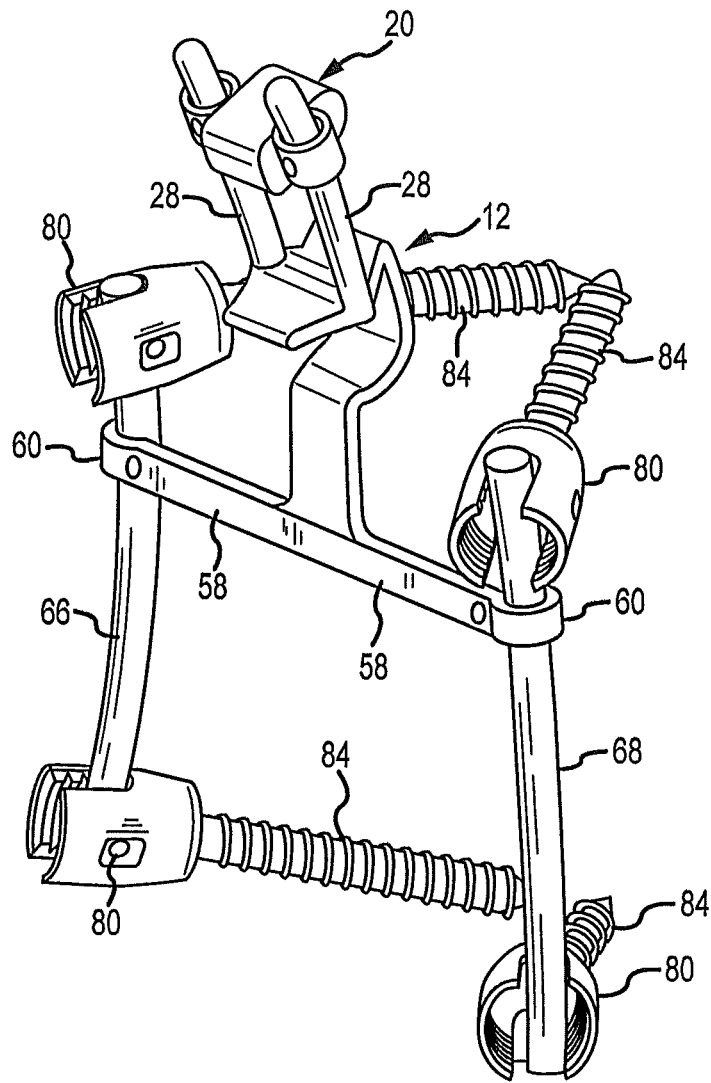

FIG. 5



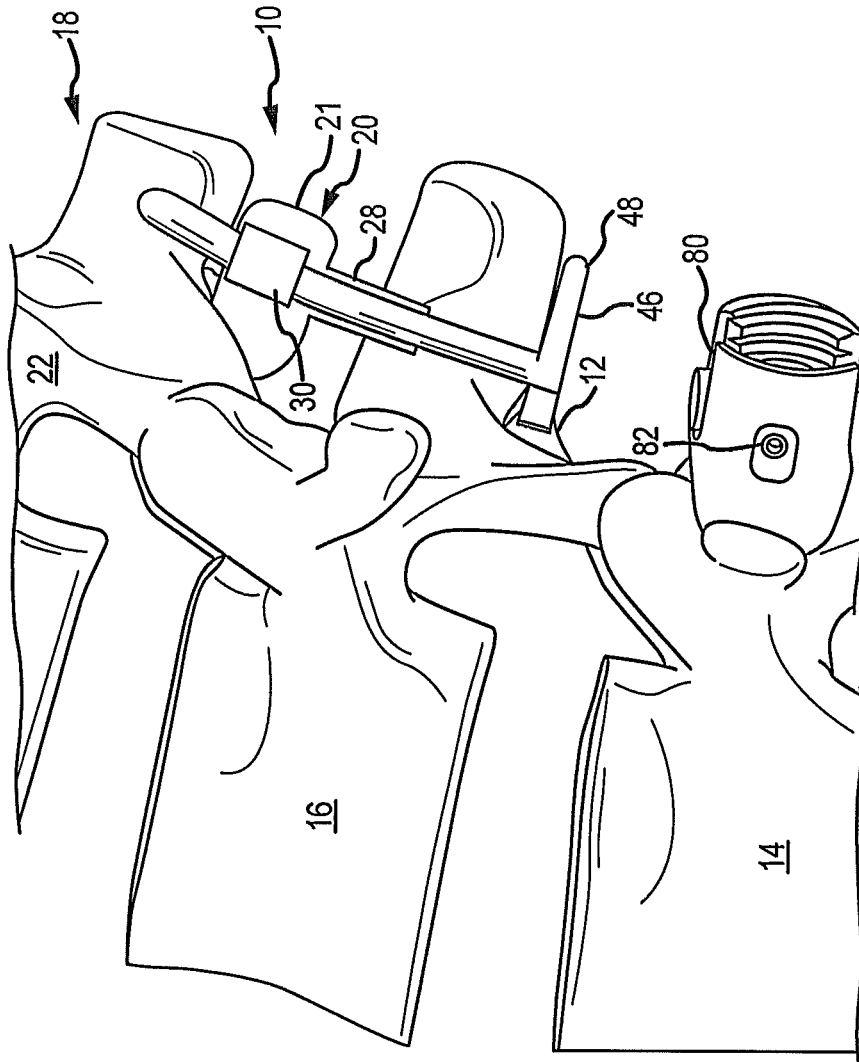

FIG.6

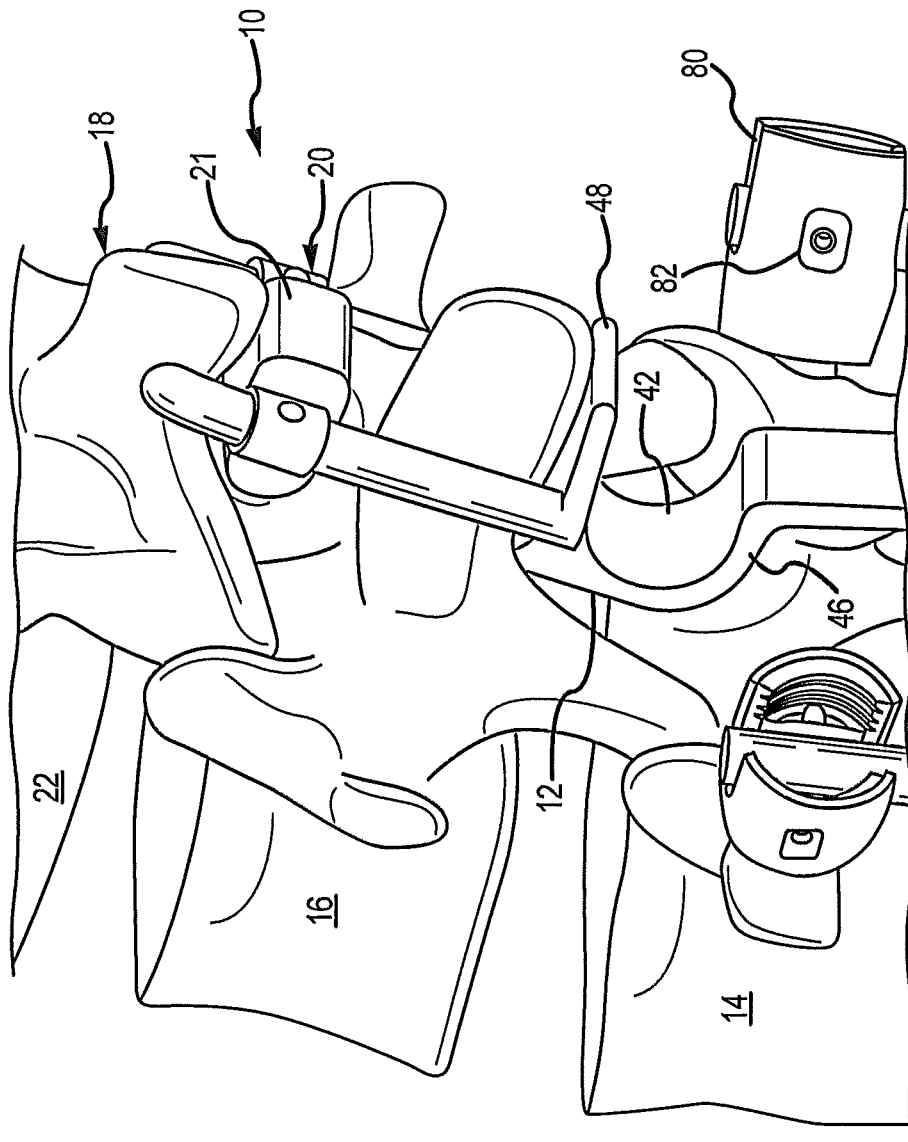

FIG.7

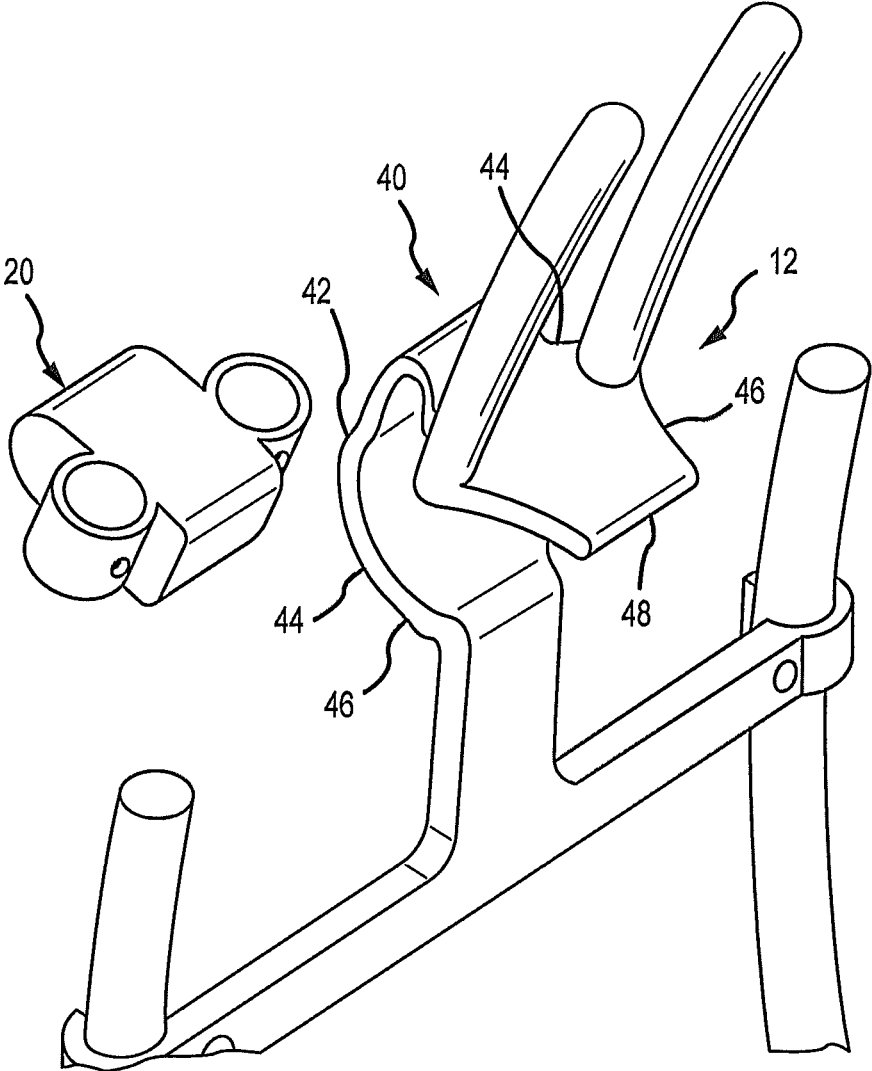

FIG.8

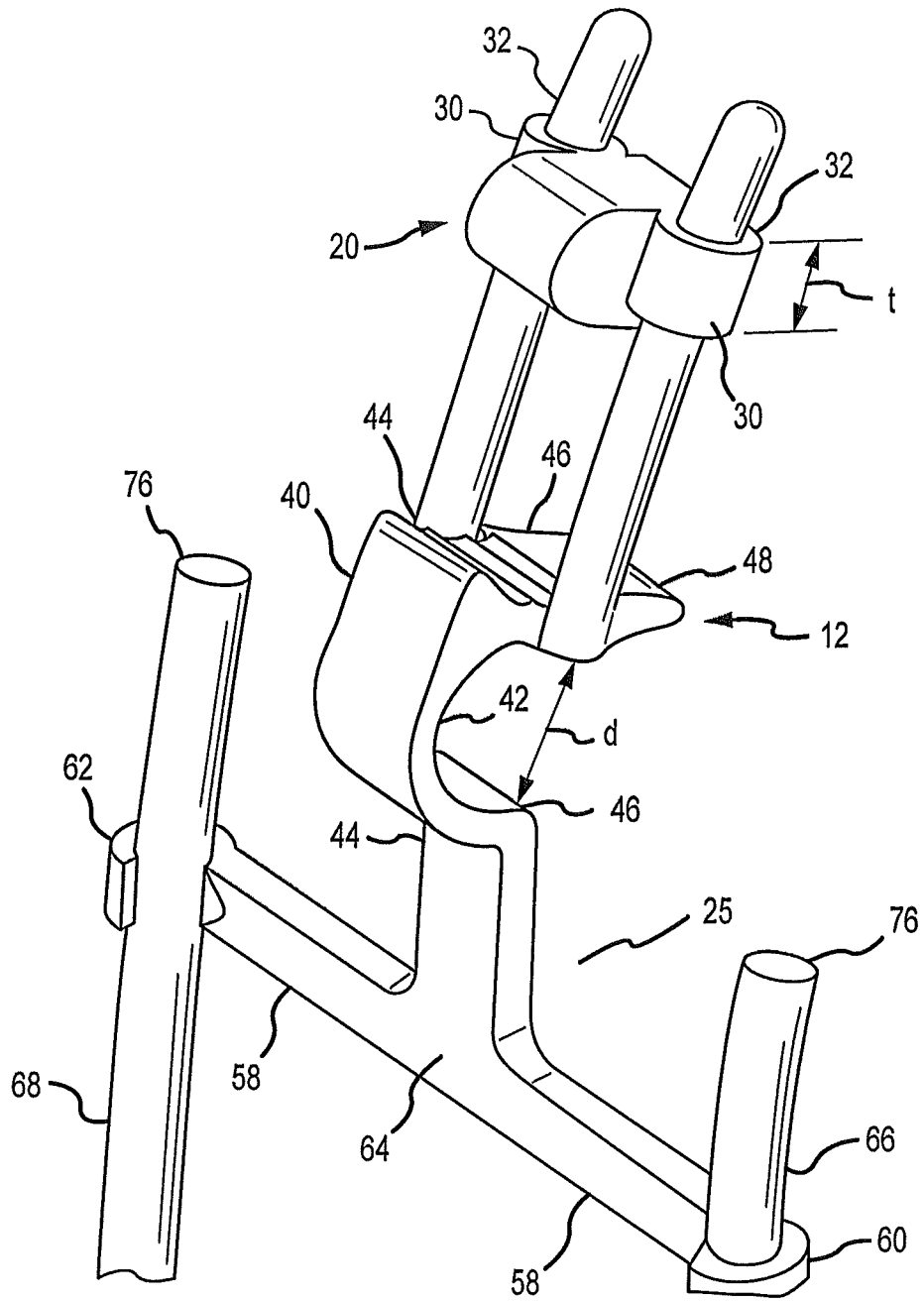

FIG. 9

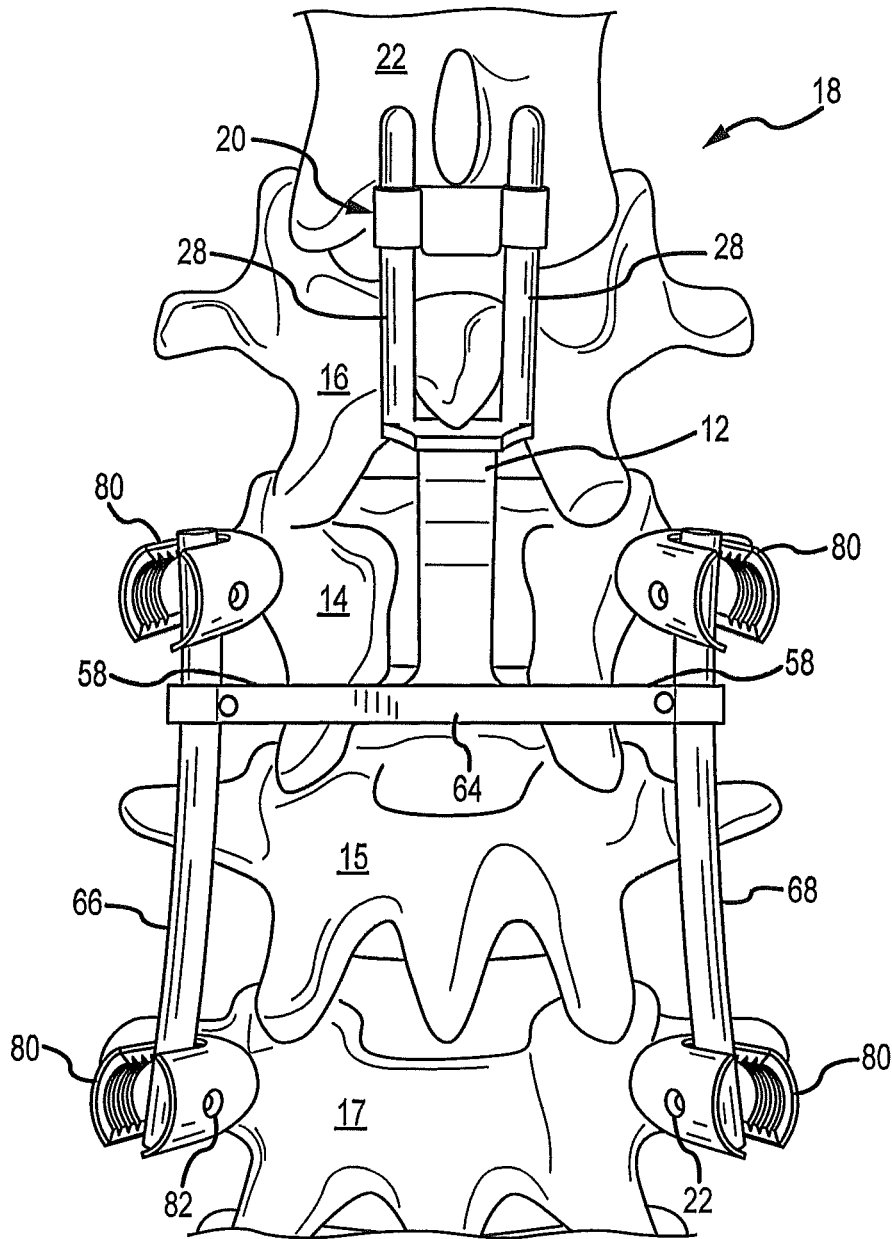

FIG. 10

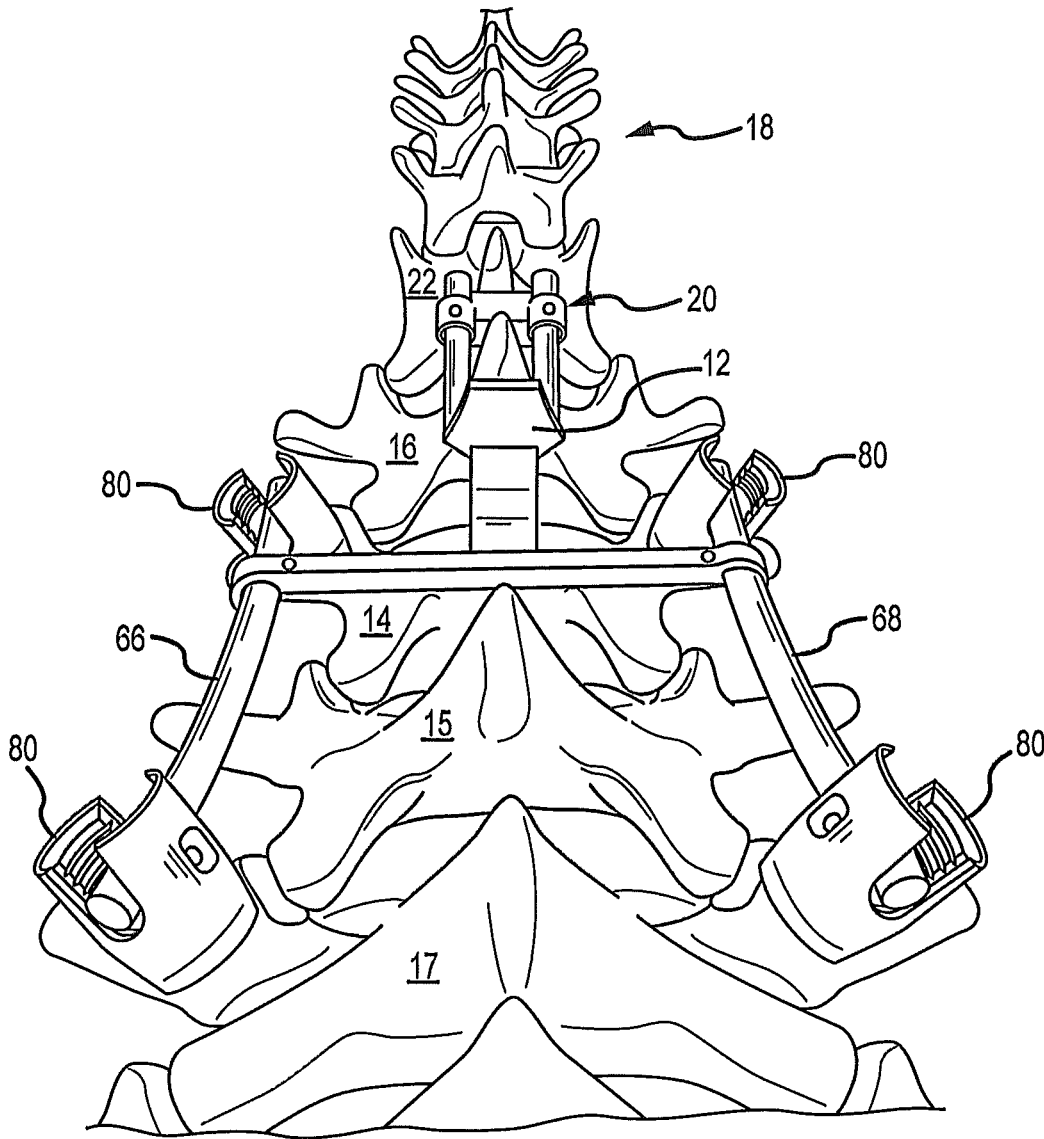

FIG.11

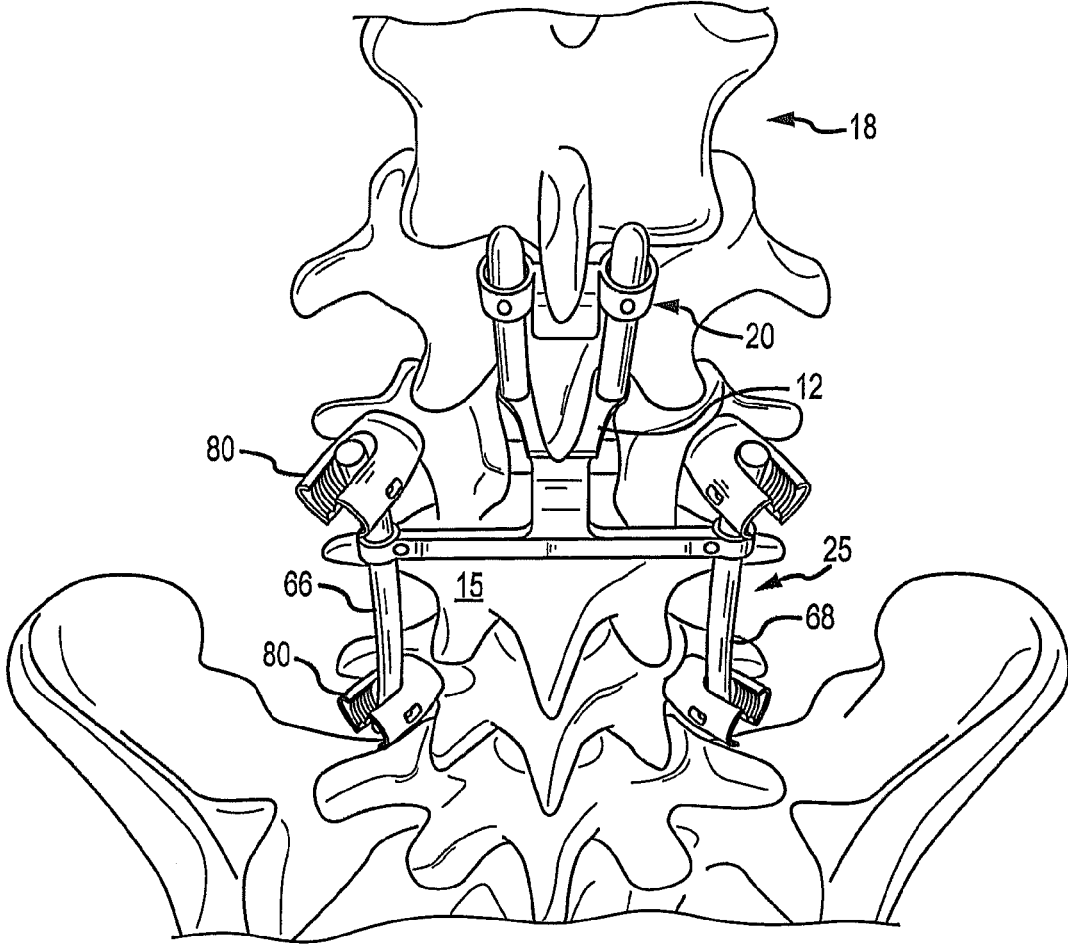

FIG.12

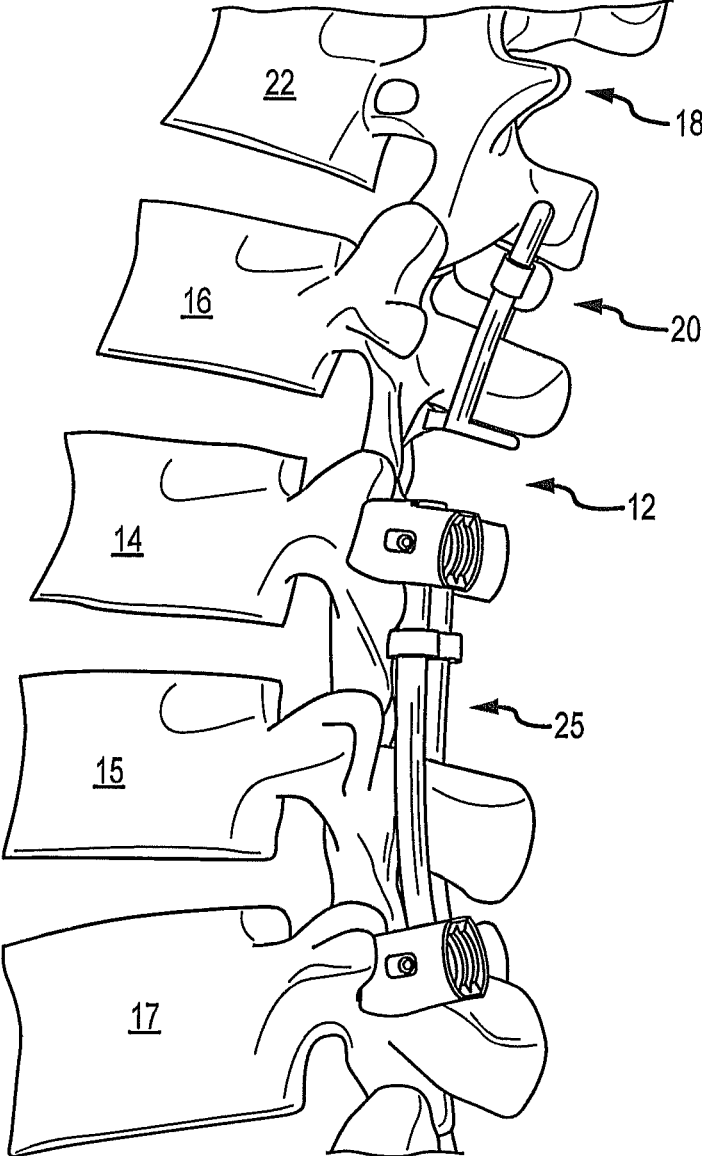

FIG.13



1

**SPINAL STABILIZATION SYSTEM****CROSS-REFERENCE TO RELATED APPLICATIONS**

This application claims priority to U.S. Provisional Application No. 61/794,543, filed Mar. 15, 2013. The entire disclosure of U.S. Provisional Patent Application No. 61/794,543 is incorporated herein by reference.

**FIELD OF THE INVENTION**

The present invention relates generally to the field of medical apparatus and methods for using the same. More specifically, the present invention relates to systems and methods for treating spinal conditions, and specifically for systems for stabilizing vertebrae in the spinal column. More specifically, the present invention relates to interlaminar vertebral stabilization devices for placement between adjacent vertebra and including supporting devices for stabilization of the vertebral segments above and below the vertebra being treated.

**BACKGROUND OF THE INVENTION**

Injury to and/or diseases of the spine frequently result in damage to or abnormalities in the vertebrae, the intervertebral discs, the facet joints and to the connective tissue and ligaments around the spine. Such damage or abnormalities may result in spinal instability causing misalignment of the vertebral column and wear of the intervertebral discs and vertebral bony surfaces, a chronic and progressive deterioration which typically results in severe pain, loss or restriction of motion, and eventually, loss of mobility of the individual suffering from the condition.

One treatment option for addressing spinal disorders is via surgical intervention and the placement of fusion, stabilization and/or repair devices on or adjacent to the spine or between adjacent vertebrae. Certain surgical procedures are irreversible, for example, fusion techniques using bone grafts or synthetic implants to fuse vertebra, and may also significantly alter vertebral range of motion. Other procedures, for example procedures for installing spinal implants or pedicle screw systems for fixating two or more vertebrae, are intricate, time consuming and highly invasive. Alternative solutions include the insertion of interspinous or intralaminar spacers in the space between adjacent vertebrae to control relative motion between and to stabilize the two vertebrae. However, the stabilization does not extend above or below the insertion point, leaving the remaining portions of the spinal column subject to unstable motion and the potential damage resulting therefrom.

Various prior art systems have attempted to address the problems described above. U.S. Pat. No. 5,645,599 issued to Samani on Jul. 8, 1977 (the '599 patent), discloses an interspinal implant device having a generally u-shaped, spring-like configuration for insertion between the spinal processes of adjacent vertebrae. Samani's device includes opposing pairs of upwardly and downwardly extending brackets adapted to be secured to the spinal process, thereby providing for flexible positioning of the adjacent vertebrae. However, the apparatus of the '599 patent does not attribute to the overall stability of the spinal column; its effect being limited to the two specific vertebrae to which it is attached. It is also difficult to attach multiple devices configured in accordance with Samani's disclosure at adjacent segments due to interference of the bracket portions.

2

Hochschuler et al disclose various intra-laminar stabilization systems in U. S. Patent Application Publication No. US 2009/0202150 published on August 13, 2009 (the '150 publication), and in U. S. Patent Application Publication No. US 2011/0106163 published on May 5, 2011 (the '163 publication). The '150 publication discloses a pair of oppositely disposed hook members that are translationally positioned on a rod and adapted to engage the laminar regions of adjacent vertebra and maintain a preselected spacing there between. However, the apparatus of the '150 publication does not stabilize other vertebrae in the spinal column, its effect being limited to the two adjacent vertebrae which it engages.

The Hochschuler et al. '163 publication discloses an interlaminar stabilizing system which includes a structure adapted to be disposed between two adjacent vertebrae as described above with respect to the apparatus of the '150 publication. The '163 structure further includes a support structure which is secured to the second vertebra to further restrict the interval spacing between the adjacent vertebrae. However, the system of the '163 disclosure also does not stabilize the vertebrae in the remaining portions of the spinal column for the reasons set forth above.

Moreover, none of the known prior art systems address the problem of "transition syndrome" or "adjacent segment disease" associated with fusion of adjacent vertebrae. In fusion, if a motion segment is eliminated via fusion, the unfused adjacent segments above and below the fused vertebrae take up and bear the additional forces induced by bending and rotational movement of the spine, which may result in so-called "transition syndrome" over the long term. In addition, none of the prior art systems provide for augmenting previously installed spinal hardware to enhance stability, adjust intervertebral distraction, and so forth.

Accordingly, a need exists for an improved spinal stabilization system which provides both flexibility and stability to the spinal column and which addresses the combination of problems not solved by the prior art.

**SUMMARY OF THE INVENTION**

It is therefore an object of the present invention to provide an improved spinal stabilization system for maintaining preselected spacing and movement between adjacent vertebrae and also for providing overall stability to the spinal column.

In one embodiment, a spinal stabilization system is provided which includes at least one interlaminar member adapted to be inserted between two adjacent vertebrae and a stabilizing structure for stabilizing the vertebrae at least one layer above and below the two adjacent vertebrae.

In another embodiment, a spinal stabilization system is provided which includes a blocking member to limit movement of adjacent vertebrae to prevent narrowing of the spinal canal and nerve compression.

In yet another embodiment, a spinal stabilization system is provided which includes at least one adjustable cross-linking member to enhance stability of the spine.

These and other objects and features of the present invention will be apparent from the accompanying description of the invention, diagrams and supplemental supporting materials provided herein.

**BRIEF DESCRIPTION OF THE DRAWINGS**

FIG. 1 is a front plan view of a spinal stabilization system of the present invention;

3

FIG. 2 is a side perspective view of a spinal stabilization system of the present invention;

FIG. 3 is a side plan view of a spinal stabilization system of the present invention;

FIG. 4 is a bottom perspective view perspective view of a spinal stabilization system of the present invention;

FIG. 5 is a top perspective view of a spinal stabilization system of the present invention;

FIG. 6 is an enlarged side plan view of a portion of the spinal stabilization system of the present invention shown in FIG. 3 showing an upper portion of the stabilization system affixed to a spinal column;

FIG. 7 is a side perspective view of a portion of the spinal stabilization system shown in FIG. 6;

FIG. 8 is an exploded front perspective view of a portion of the spinal stabilization system shown in FIGS. 6 and 7;

FIG. 9 is an exploded rear perspective view of a portion of the spinal stabilization system shown in FIGS. 6, 7 and 8;

FIG. 10 is a front plan view of a spinal stabilization system of the present invention affixed to a spinal column;

FIG. 11 is a bottom front perspective view of a spinal stabilization system of the present invention affixed to a spinal column;

FIG. 12 is a top front perspective view of a spinal stabilization system of the present invention affixed to a spinal column;

FIG. 13 is a side perspective view of a spinal stabilization system of the present invention affixed to a spinal column.

#### DESCRIPTION OF THE INVENTION

It should be noted that the present description is by way of illustration only, and that the concepts and examples presented herein are not limited to use or application with any single system or methodology. Hence, while the details of the system and methods described herein are for the convenience of illustration and explanation with respect to the exemplary embodiments, the principles disclosed may be applied to other types of spinal stabilization systems without departing from the scope of the present invention.

Referring now to FIG. 1, a spinal stabilization system according to an embodiment of the present invention is shown generally at 10 (which for purposes of brevity will be referred to herein as "the system"). The system includes a first interlaminar member 12 adapted to be positioned between adjacent vertebra in a spinal column. As shown in greater detail in FIGS. 6 and 7, the interlaminar member 12 is shown positioned between a first vertebra 14 and a second adjacent vertebra 16 in a spinal column 18.

The system further includes a second interlaminar member 20 adapted to be positioned between the second vertebra 16 and a third vertebra 22 in the spinal column 18. Both the first and second interlaminar members are operatively connected to a support structure shown generally at numeral 25 in FIG. 1. By way of example, in the embodiment shown, the support structure and the first interlaminar member are integrally formed from a single piece of material such as titanium or stainless steel suitable for use as a medical implant device. However, it is to be understood that other means for connecting the interlaminar device to the support structure such as hinges, pins, threaded fasteners and the like may also be used without departing from the scope of the invention.

The support structure 25 comprises a pair of support members or guide rods 28 secured to the first interlaminar support member 12 and extending in a direction upwardly therefrom substantially parallel to one another. The second

4

interlaminar member 20 includes a body portion 21 of a preselected thickness  $t$ , which is most clearly illustrated in FIG. 9. Thickness  $t$  is selected based upon the spacing between the second and third vertebrae and is intended to be smaller in size than the spacing to allow for flexion of the spinal column 18.

The body portion 21 further includes a pair of oppositely positioned ears 30 extending laterally outwardly from the body portion in opposing directions, each of the ears containing an aperture 32 structured and arranged to slideably receive one of the support members or guide rods 28. As will be discussed in greater detail below, the second interlaminar member is movably supported by upwardly extending support members or guide rods, and the position of the second interlaminar member 20 relative to the first interlaminar member 12 may be adjusted depending upon the dimensions of the specific spinal column on which the system is installed and the range of motion desired. Once the position of the second interlaminar member 20 has been selected, it is locked in place by a pair of set screws or other suitable fastening means 34 extending through each of the ears 30 and adapted to releaseably engage the respective guide rod extending therethrough.

Referring now to FIGS. 2, 3, 7 and 8, the first interlaminar member is 12 depicted in greater detail. The first interlaminar member comprises a U-shaped body 40 defined by an elastic midsection 42, two spaced apart end portions 44, and a pair of juxtaposed legs 46, each leg extending substantially parallel to one another from one of the respective ends in a direction generally outwardly away from the spinal column 18 (FIG. 7) and spaced apart a preselected distance  $d$ . Distance  $d$  is determined by the size of the first interlaminar member, which is, in turn, is selected based upon the spacing between the first and second vertebrae. The first interlaminar member is intended to fuse the first and second vertebrae. Accordingly, it is sized to be a tight fit, and the elastic properties of the U-shaped body 40 act as a spring or shock absorber in the interface between the two vertebrae. Further, the uppermost one of the legs 46 is longer than the lower one of the legs, thereby forming a handle 48 which may be used to insert and position the system during surgery.

Referring again to FIG. 1, the support structure 25 further includes a T-shaped frame member 50 operatively connected to the first and second interlaminar members 12 and 20 and extends generally downwardly therefrom in a direction substantially parallel to the spinal column 18. The T-shaped frame member has comprises an elongate body 52 having first and second end portions 54, 56, the first end portion being operatively connected to the first interlaminar member 12, and an elongate cross member 58. The cross member has first and second end portions 60, 62 and a midpoint 64 and is structured and arranged to be connected to the second end portion 56 of the body 52 at approximately the midpoint 64. Each of the ends 60, 62 of the cross member 58 are adapted to receive and adjustably secure first and second support members 66 and 68 respectively. In the embodiment shown, each of the end portions 60, 62 have an aperture 70, 72 formed therein respectively for receiving one of the support members 66, 68, each of which may be held in a preselected position by a set screw 74.

In the embodiment shown, by way of example only and not of limitation, the support members are in the form of guide rods 66, 68, each guide rod having an upper end 76 and a lower end 78. Each of the upper and lower ends of the support members 66, 68 has a securing device 80 slideably positioned thereon and adapted to be secured thereto by means of set screws 82. By way of example, each of the

securing devices is shown in the form of a pedicle screw **84**, each pedicle screw being structured and arranged to be secured to one of the vertebrae of the spinal column **18**.

The installation and operation of the spinal support system **10** of the present invention are illustrated in greater detail in FIGS. **6**, **7**, and **10-13**. The system advantageously may be installed where other spinal fusion devices or similar medical apparatus are already in place to add stability to the spinal column above and below the installation point, to control flexion and/or rotational movement of the spine or selected vertebrae with respect to one another, and to prevent impingement of adjacent vertebrae, spinal processes, pedicle screws and medical hardware on one another. By way of example, as best shown in FIGS. **6** and **7**, a surgeon may insert the system **25** into the space between adjacent vertebrae **14** and **16** by gripping handle **48** and making the insertion. The tight fitting U-shaped body **40** not only serves to control any motion between the adjacent vertebrae or even eliminate it entirely, thereby effectively fusing the vertebrae, but also serves as a dampening cushion or spring device by virtue of the spring-like elasticity of the body **40** translated to the vertebrae via legs **46**. Thereafter, the second interlaminar member **20** may be selectively positioned intermediate vertebra **16** and vertebra **22** to permit flexion on a forward direction but to limit extension in the rearward direction and to limit compression of the spinal segment, thereby imparting enhanced stability to the spinal column above the fused vertebrae.

In a similar manner, support structure **25**, via the T-shaped frame member **50** and support members or guide rods **66** and **68**, provides support to the spinal processes located below the fused vertebrae **14** and **16**. As shown in FIGS. **10-13**, the pedicle screws **80** may be positioned in first vertebra **14** and in either vertebra **15** immediately adjacent to vertebra **14**, or at a lower level as shown by vertebra **17**, thus extending the stabilizing effect of the novel support system of the present invention to multiple levels in the spinal column **18**. More than one level may be addressed simply by lengthening the rods **66** and **68** and slideably positioning multiple pedicle screws **80** thereon for selective positioning along the spinal column.

In one aspect, the cross member midpoint **64** may be configured, structured and arranged to be adjustably (e.g., pivotably or translatably) connected or secured to the second end portion **56** of the body **52** at approximately the midpoint **64** in order to allow a surgeon during the course of the surgical procedure to adjust and align components of the implant in relation to the patient's bony anatomy and in relation to support members **66** and **68**.

In another aspect, elongate body **52** may be comprised of multiple pieces. For example, one or more linear racks may be configured in operable relation with gear mechanisms, thereby forming a ratchet device (not shown), in order to extend the distance between first and second end portions **54** and **56** thereby permitting a surgeon during the course of the surgical procedure to adjust and align components of the implant in relation to the patient's bony anatomy and subsequently securing them in place. For example, a ratchet mechanism configuration may permit the surgeon to progressively extend elements of the implant to better appose a lamina.

In yet another aspect, each of the ends **60**, **62** of the cross member **58** may be configured to permit a degree of adjustability (e.g., pivotably or translatably) to receive and adjustably secure first and second support members **66** and **68** respectively. For example any cross-link variable adjustment mechanism or fastener known in the art may be employed to

accomplish the desired fixation between the ends **60**, **62** of the cross member **58** and first and second support members **66** and **68**.

According to particular embodiments, interlaminar member **20** may be configured to permit connection to guide rods **28** via an approach that is substantially perpendicular to the longitudinal axis of guide rods **28**. In other words, after the other components of the system have been implanted via a posterior approach to the posterior aspect of the spine the interlaminar member **20** may follow a generally similar approach trajectory and then secured to the guide rods **28** with, e.g., set screws in a similar manner to the engagement between the ends **60**, **62** of the cross member **58** and first and second support members **66** and **68**. Furthermore, in another aspect, an interlaminar member **20** may be used alone (and may alternatively be configured to be similar to the U-shaped body **40**) and may be directly engaged with a first and second support members **66** and **68** and positioned between the lamina and spinous processes of the spine.

In particular aspects, the different elements of the system may be configured with tool engagement features in order to permit a surgeon to grasp the implant with a tool assembly or insertion tool to ease implantation of the various components. For example, the insertion tool may be configured as a pair of pliers or hemostats. As another example, a threaded portion of a tool assembly may reversibly secure to a complementary threaded portion of the implant in order to ease implantation. E.g., a tool assembly may be comprised of a cannulated shaft with a retainer shaft housed substantially within, the retainer shaft further configured with a threaded portion at its distal end which may extend out of a distal end of the retainer shaft and a handle located and attached to a proximal end of the retainer shaft; the distal end of the retainer shaft may have a feature that permits rotation of the retainer shaft via another tool, such as the mechanical arrangement that exists between a wrench and nut, in order to secure the tool assembly to the implant. After implantation of the implant the tool assembly may be decoupled and removed.

Changes may be made in the above methods and systems without departing from the scope hereof. It should thus be noted that the matter contained in the above description and/or shown in the accompanying figures should be interpreted as illustrative and not in a limiting sense. The following claims are intended to cover all generic and specific features described herein, as well as all statements of the scope of the present systems and methods, which, as a matter of language, might be said to fall there between.

What is claimed is:

1. A spinal stabilization system comprising:
  - a first interlaminar member adapted to be positioned between a first vertebra and a second vertebra in a spinal column; the first interlaminar member including a U-shaped body having a midsection, and two spaced apart end portions, and a pair of juxtaposed legs extending substantially parallel to one another from one of the respective ends in a direction generally outwardly away from the spinal column;
  - a second interlaminar member adapted to be positioned between the second vertebra and a third vertebra positioned adjacent to and above the first vertebra in the spinal column; and
  - a support structure operatively connected to the first and second interlaminar members, the first vertebra and at least one vertebra positioned below the first vertebra in the spinal column, the support structure including a T-shaped frame member operatively connected to the

7

first and second interlaminar members and extending generally downwardly therefrom in a direction substantially parallel to the direction of the spinal column, the T-shaped frame member including an elongate body having first and second end portions, the first end portion being operatively connected to the first interlaminar member, and an elongate cross member having first and second end portions and a midpoint, the elongate cross member being operatively connected approximately at the midpoint to the second end portion of the body.

2. The system of claim 1 wherein the support structure includes a pair of support members secured to the first interlaminar member extending upwardly therefrom in a direction substantially parallel to one another.

3. The system of claim 2 wherein the second interlaminar member is moveably supported by the upwardly extending support members.

4. The system of claim 3, wherein the second interlaminar member is adjustably movable to a preselected position on the upwardly extending support members relative to the first interlaminar member in response to a dimension of the spinal column and a range of motion desired, and wherein the system further includes a fastener adapted to secure the position of the second member relative to the support member such that once the position of the second interlaminar member has been selected, the second interlaminar member is locked in place relative to the support members by the fastener.

5. The system of claim 4, wherein the second interlaminar member includes a body portion configured to support the fastener whereby the fastener extends through the body portion and is adapted to releasably engage a support member of the pair of support members when extending therethrough.

6. The system of claim 2, wherein the second interlaminar member includes a body portion comprising a pair of oppositely positioned ears extending laterally outwardly from the body portion in opposing directions, each of the ears including an aperture formed therein, each aperture being structured and arranged to slideably receive one of the support members.

7. The system of claim 1, wherein the elongate cross member is adjustably connected to the second end position of the body, whereby the elongate cross member is pivotally or translatably movable with respect thereto.

8. The system of claim 7, wherein the elongate body includes at least one linear rack, the rack being structured and arranged to progressively extend the distance between the first and second end portions of the elongate body of the T-shaped frame member.

9. The system of claim 8, further including a gear mechanism operatively connected to the at least one linear rack, the gear mechanism and the at least one linear rack forming a ratchet device configured to permit the progressive extension.

10. The system of claim 1 wherein the second interlaminar member is structured and arranged to fit loosely between the second vertebra and the third vertebra.

11. The system of claim 10, wherein the second interlaminar member includes a body portion of a preselected thickness, the preselected thickness being based upon spacing between the second and third vertebrae whereby the preselected thickness of the body portion is smaller in size than the spacing to allow for a flexion of a portion of the spinal column.

8

12. The system of claim 1 further including first and second support members adjustably secured to the first and second ends of the elongate cross member respectively.

13. The system of claim 12 where each of the first and second support members includes an upper and a lower end, each of the upper and lower ends having a securing device slideably positioned thereon, each securing device being structured and arranged to be secured to a vertebra in the spinal column.

14. The system of claim 1, wherein the pair of juxtaposed legs comprises an uppermost leg and a lowermost leg, the first end portion of the elongate body being operatively connected to the first interlaminar member at the lowermost leg and wherein the uppermost leg is longer than the lowermost leg.

15. The system of claim 14, wherein the uppermost leg forms a handle adapted to facilitate insertion and positioning of the system during surgery.

16. The system of claim 1 wherein the first interlaminar member is structured and arranged to fit tightly between the first vertebra and the second vertebra.

17. The system of claim 1, wherein the midsection is elastic.

18. The system of claim 1, wherein the support structure and the first interlaminar member are integrally formed from a single piece of material.

19. The system of claim 1, further including means for connecting the first interlaminar member to the support structure, the connecting means comprising at least one of: a) a hinge; b) a pin; or c) a threaded fastener.

20. The system of claim 1, wherein each of the first and second end portions of the elongate cross member comprises a variable adjustment mechanism configured to pivotably or translatably receive and adjustably secure to the first and second support members.

21. A system for treating a patient's spinal column, the system comprising:

a spinal stabilization system including a first interlaminar member adapted to be positioned between a first vertebra and a second vertebra in a spinal column; the first interlaminar member including a U-shaped body having a midsection, and two spaced apart end portions, and a pair of juxtaposed legs extending substantially parallel to one another from one of the respective ends in a direction generally outwardly away from the spinal column;

a second interlaminar member adapted to be positioned between the second vertebra and a third vertebra positioned adjacent to and above the first vertebra in the spinal column; and

a support structure operatively connected to the first and second interlaminar members, the first vertebra and at least one vertebra positioned below the first vertebra in the spinal column, the support structure including a T-shaped frame member operatively connected to the first and second interlaminar members and extending generally downwardly therefrom in a direction substantially parallel to the direction of the spinal column, the T-shaped frame member including an elongate body having first and second end portions, the first end portion being operatively connected to the first interlaminar member, and an elongate cross member having first and second end portions and a midpoint, the elongate cross member being operatively connected approximately at the midpoint to the second end portion of the body and

an insertion tool configured to reversibly secure to a tool engagement portion of the spinal stabilization system, the insertion tool being adapted to permit a surgeon to grasp the system with the insertion tool whereby implantation of the system in the patient's spinal column is facilitated. 5

**22.** The system of claim **21**, wherein the insertion tool comprises a pair of pliers or hemostats.

**23.** The system of claim **22**, wherein the tool engagement portion includes a threaded portion and wherein the insertion tool includes a threaded portion configured to reversibly secure to the threaded portion of the tool engagement portion of the spinal stabilization system. 10

**24.** The system of claim **23**, wherein the insertion tool includes a cannulated shaft and a retainer shaft housed substantially within the cannulated shaft, the retainer shaft including a distal end and a proximal end opposite the distal end, the distal end of the retainer shaft comprising the threaded portion thereof and the proximal end of the retainer shaft comprising a handle. 15 20

\* \* \* \* \*

UNITED STATES PATENT AND TRADEMARK OFFICE

**CERTIFICATE OF CORRECTION**

PATENT NO. : 9,510,872 B2  
APPLICATION NO. : 14/209138  
DATED : December 6, 2016  
INVENTOR(S) : Donner et al.

Page 1 of 1

It is certified that error appears in the above-identified patent and that said Letters Patent is hereby corrected as shown below:

Column 7, Line 45 should read:  
member is adjustably connected to the second end portion

Signed and Sealed this  
Thirteenth Day of June, 2017

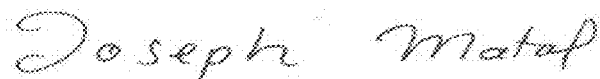
A handwritten signature in black ink that reads "Joseph Matal". The signature is written in a cursive style with a large initial "J".

Joseph Matal  
*Performing the Functions and Duties of the  
Under Secretary of Commerce for Intellectual Property and  
Director of the United States Patent and Trademark Office*

UNITED STATES PATENT AND TRADEMARK OFFICE  
**CERTIFICATE OF CORRECTION**

PATENT NO. : 9,510,872 B2  
APPLICATION NO. : 14/209138  
DATED : December 6, 2016  
INVENTOR(S) : Edward Jeffrey Donner and Christopher Thomas Donner

Page 1 of 1

It is certified that error appears in the above-identified patent and that said Letters Patent is hereby corrected as shown below:

In the Specification

Please correct Column 1, Line 55 to read as follows:

Samani on July 8, 1997 (the '599 patent), discloses an

Please correct Column 2, Line 3 to read as follows:

US 2009/0204150 published on August 13, 2009 (the '150

Please correct Column 3, Lines 5-6 to read as follows:

Fig. 4 is a bottom perspective view of a spinal stabilization system of the present invention;

Please correct Column 4, Line 33 to read as follows:

member, which, in turn, is selected based upon the spacing

Please correct Column 4, Line 47 to read as follows:

frame member includes an elongate body 52 having

Signed and Sealed this  
Fourteenth Day of August, 2018



Andrei Iancu  
Director of the United States Patent and Trademark Office